

A+ A-PLUS

MANUFACTURING COMPANY

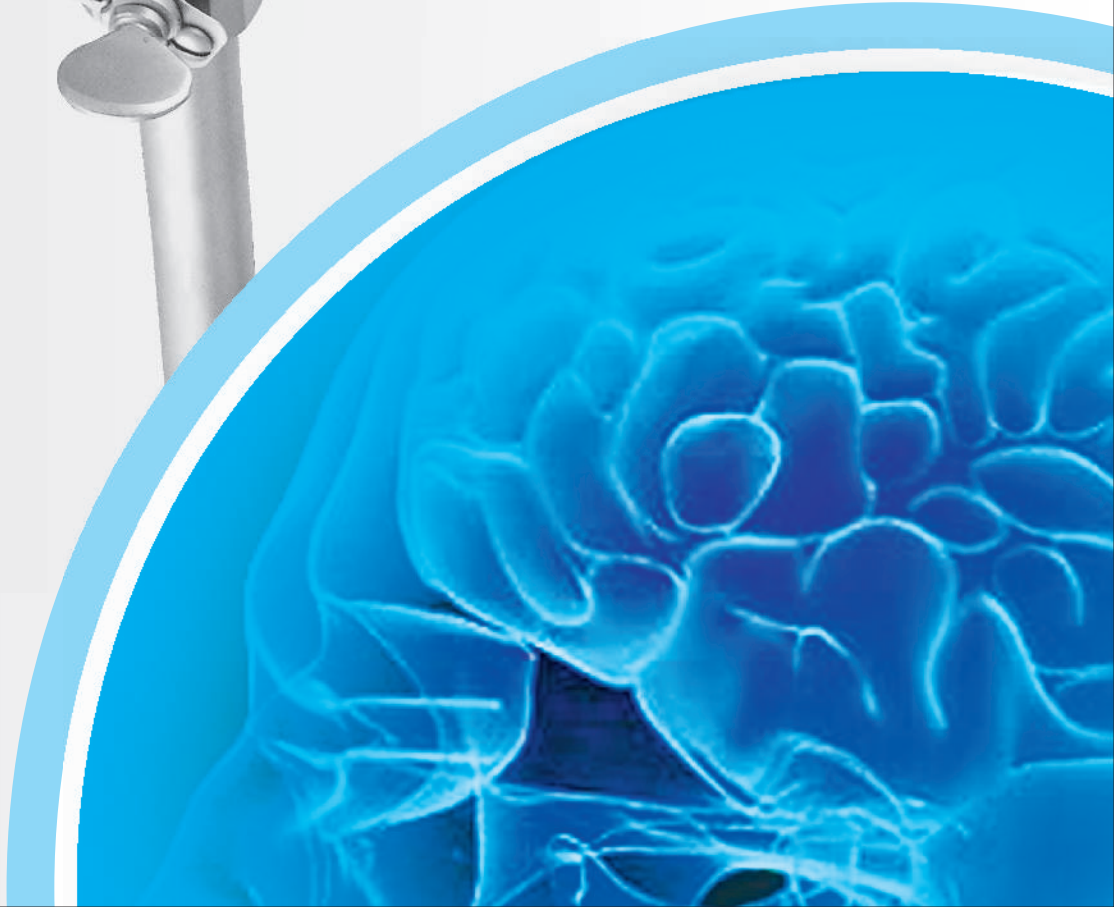
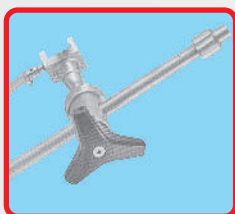
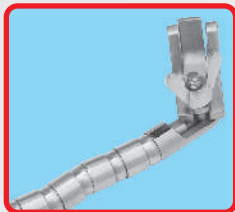

www.aplus.com.pk

Neuro and Laminectomy Instruments

Instrumentns for Crenial Opening
Instrumentns für Crenial Eröffnung

Instrumentns concernant l'ouverture Crenial
Instrumentns para la Apertura de Crenial



Gigli
AP-2305-00

Wire Saws
Seilsägen
Scies à fil
Sierras de cable

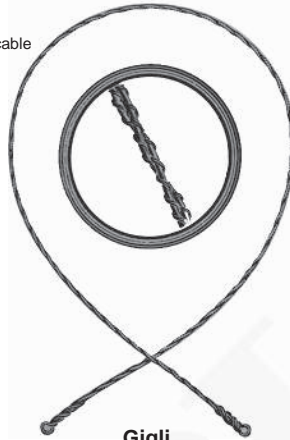

Gigli
AP-2306-30 30 cm/12"
AP-2306-40 40 cm/16"
AP-2306-50 50 cm/20"



Conductors
Leiter
conducteurs
conductores

Martel
AP-2307-33
33 cm/13"



With 2 Extra Hooks
Mit 2 Extra Haken
Avec 2 crochets supplémentaires
Con 2 ganchos adicionales

Dahlgren
AP-2308-20
20 cm/8"

Skull Cutting Forceps
Schädel Cutting Forceps
Pince coupe de crâne
Pinzas de corte del cráneo



With 1 Hook Each
Mit 1 pro Haken
Avec 1 crochet Chaque
Con un gancho Cada

De Vilbiss
AP-2309-21
21 cm/8¼"

Neuro and Laminectomy Instruments

Cervical Traction Tongs
Halswirbeltraktionsgerät Zange

Pince de traction cervicale
Pinzas de tracción cervical



AP-2310-00

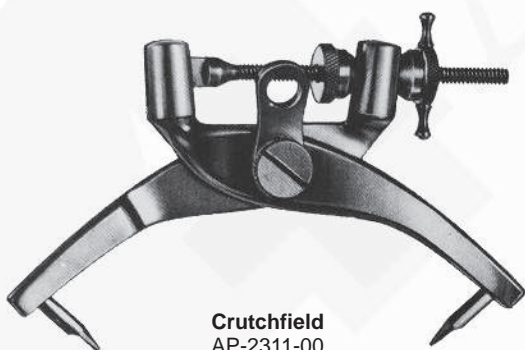

Crutchfield
AP-2311-00

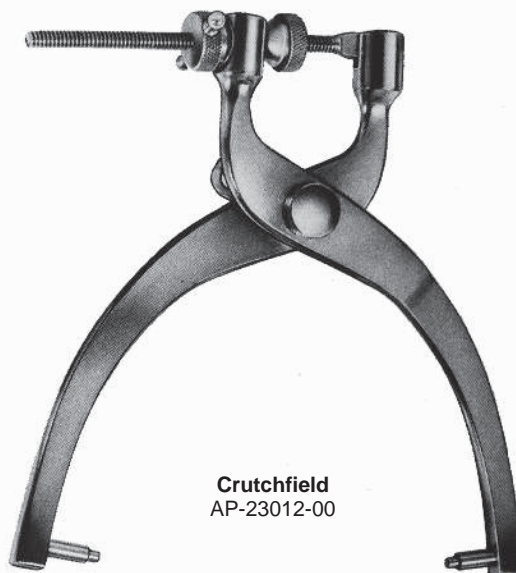

Crutchfield
AP-23012-00

Neuro and Laminectomy Instruments

Instrument for Brain Suture
Instrument für Brain Suture

Instrument pour Suture cerveau
Instrument para la sutura del cerebro

Applying and Removing Forceps
Auftragen und Entfernen von Pinzetten
Application et suppression forceps
La aplicación de fórceps y extracción

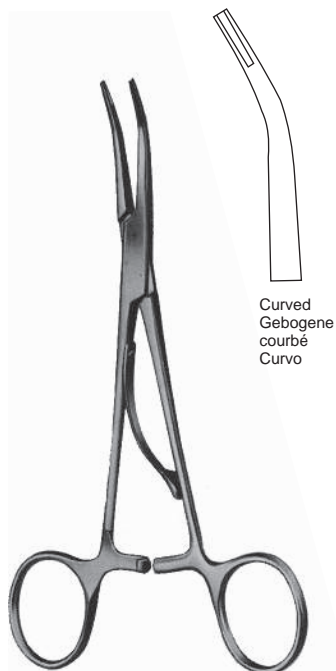

Curved
Gebogene
courbé
Curvo

McKenzie
AP-2313-15 15 cm/6"
AP-2313-19 19 cm/7½"



Straight
gerade
droit
recto

McKenzie
AP-2314-15 15 cm/6"
AP-2314-19 19 cm/7"



Raney
AP-2315-00
16 cm/6¼"



Olivecrona-Tonnis
AP-2316-14

Neuro and Laminectomy Instruments

Dura Dissectors
harte Dissektoren

dissecteurs durs
dura disector



AP-2317-26
26 cm/10¼"

Toennis



AP-2318-18
18 cm/7 "

Olivecrona



AP-2319-20
20 cm/8 "

Olivecrona



AP-2320-21
20.5 cm/8 "

Sachs

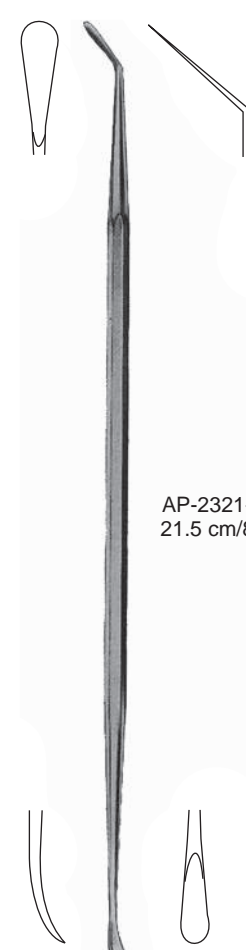

AP-2321-21
21.5 cm/8½"

Milligan

Neuro and Laminectomy Instruments

Dura Dissectors
harte Dissektoren

dissecteurs durs
dura disector



AP-2322-21
21.5 cm/8½"

Davis

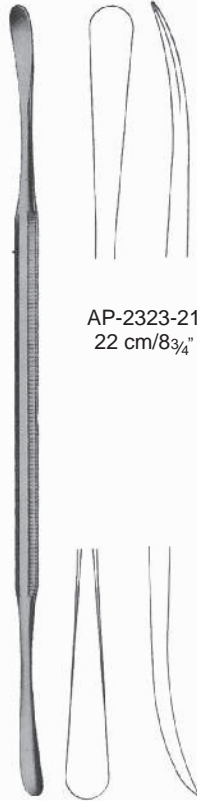

AP-2323-21
22 cm/8¾"

AP-2323-21
22 cm/8¾"



AP-2324-01
17.5 cm/7"
Fig. 1

Penfield

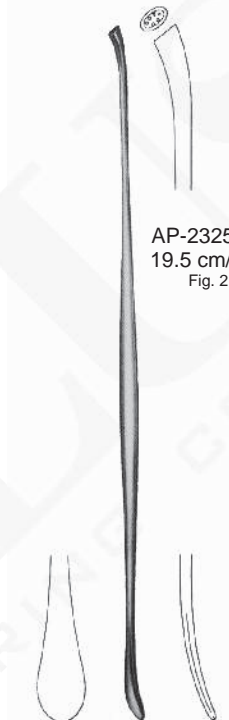

AP-2325-02
19.5 cm/7¾"
Fig. 2

Penfield



AP-2326-03
19.5 cm/7¾"
Fig. 3

Penfield



AP-2327-04
20.5 cm/8"
Fig. 4

Penfield

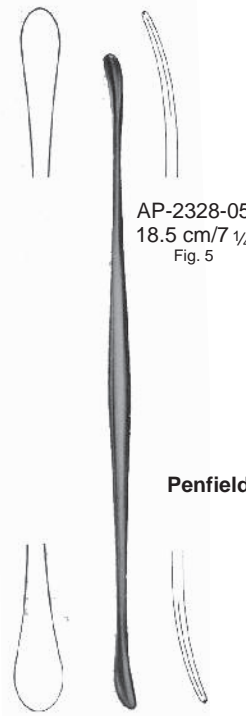

AP-2328-05
18.5 cm/7 ¼"
Fig. 5

Penfield

Neuro and Laminectomy Instruments

Dura Dissectors, Nerve Root Retractors and Brain Spatulas

Dura Dissektoren, Nervenwurzel Retraktoren und Brain Spatel

Dissecteurs Dura, Rétracteurs racine nerveuse et Brain Spatules

Dura disectores, Retractores raíz del nervio y Espátulas cerebrales



AP-2329-24
24.5 cm/9 3/4"



AP-2330-21
21.5 cm/8 1/2"



AP-2331-18
18 cm/7"

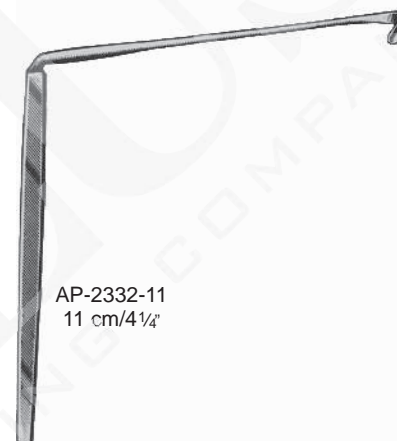

AP-2332-11
11 cm/4 1/4"

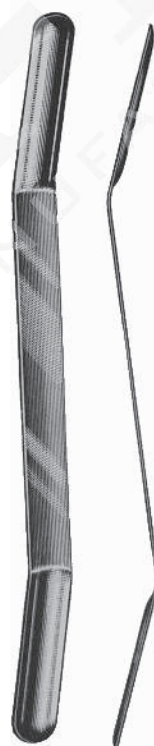

Upper end

Lower end



Olivecrona
18 cm/7"

Width of Spatulas
Breite Spatel
Largeur des Spatules
Ancho de espátulas

	Concave	mm	mm	Convex
AP-2333-01		7	9	AP-2334-01
AP-2333-02		11	13	AP-2334-02
AP-2333-03		15	18	AP-2334-03
AP-2333-04		18	22	AP-2334-04

Neuro and Laminectomy Instruments

Nerve Root Retractors
Nervenwurzel Retraktoren

Rétracteurs des racines nerveuses
Los retractoros de las raíces nerviosas



AP-2335-23
23.5 cm/9 1/4"

scoville



AP-2336-24
23.5 cm/9 1/4"

Holsher



AP-2337-16
23.5 cm/9 1/2"

Scoviller

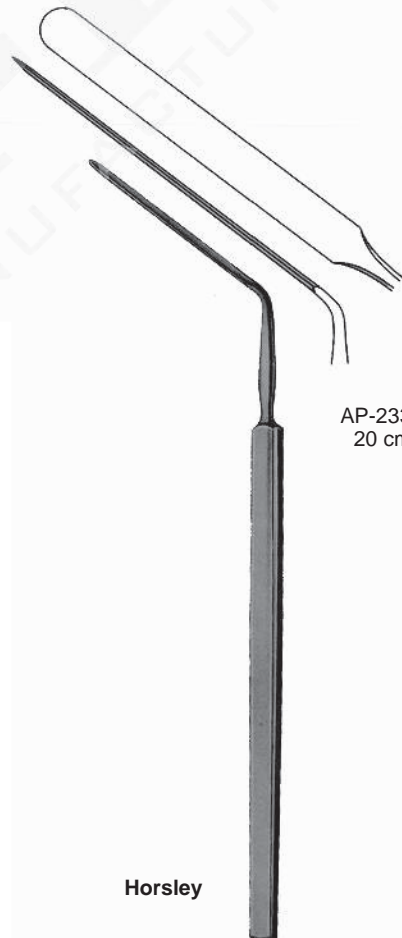

AP-2338-20
20 cm/8 "

Horsley

Neuro and Laminectomy Instruments

Brain and Elevators
Gehirn und Aufzüge

Cerveau et Ascenseurs
Cerebro y Elevadores



20 cm/8"
14 mm AP-2339-14
17 mm AP-2339-17
20 mm AP-2339-20



AP-2340-21
21 cm/8 1/4"



AP-2341-21
21 cm/8 1/4"

Sachs

Neuro and Laminectomy Instruments

Nerve Hooks
Nerve Haken

Crochets nerveuses
Ganchos nerviosas

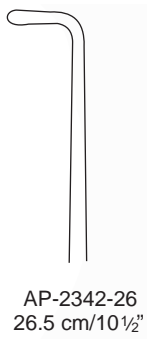

AP-2342-26
26.5 cm/10½"

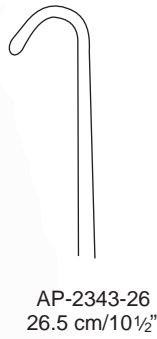

AP-2343-26
26.5 cm/10½"



Groningen



AP-2344-19
19 cm/7½"
Fig. 1

AP-2344-28
28 cm/11"
Fig. 2

Cushing



AP-2345-19
19.5 cm/7"
Fig. 1

AP-2345-28
28 cm/11"
Fig. 2

Cushing



Smithwick



AP-2346-17
17 cm/6¾"



AP-2346-21
21 cm/8¼"



Dandy

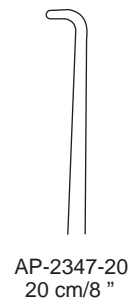

AP-2347-20
20 cm/8"



Neuro and Laminectomy Instruments

Dura Knives, Dura Hooks
Messer Dura, Dura Haken

Couteaux Dura Dura, les crochets
Dura Dura cuchillos, ganchos

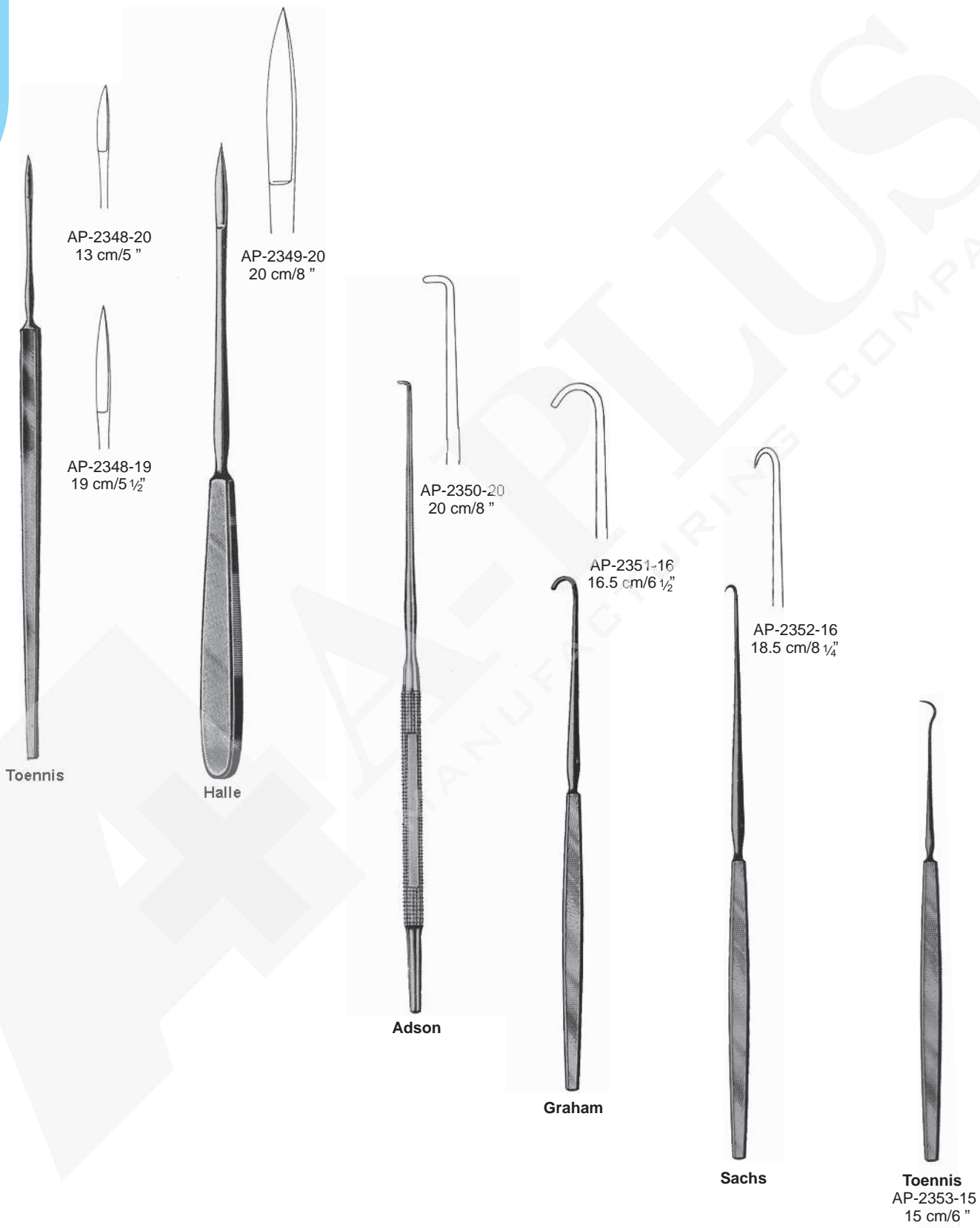

AP-2348-20
13 cm/5 "

AP-2349-20
20 cm/8 "

AP-2348-19
19 cm/5 ½"

AP-2350-20
20 cm/8 "

AP-2351-16
16.5 cm/6 ½"

AP-2352-16
18.5 cm/8 ¼"

Toennis

Halle

Adson

Graham

Sachs

Toennis
AP-2353-15
15 cm/6 "

Neuro and Laminectomy Instruments

Blades for Lamina Spreaders
Klingen für Lamina Spreader

Lames pour Epandage Lamina
Cuchillas para Esparcidores Lamina

Lateral
seitlich
latérale
lateral



mm

AP-2354-40 40 x 20
AP-2354-45 45 x 20
AP-2354-50 50 x 20
AP-2354-55 55 x 20
AP-2354-60 60 x 20



mm

AP-2355-40 40 x 20
AP-2355-45 45 x 20
AP-2355-50 50 x 20
AP-2355-55 55 x 20
AP-2355-60 60 x 20



mm

AP-2356-50 50 x 25
AP-2356-60 60 x 25

Blunt Blades, For Taking
stumpfen Klingen, für die Aufnahme
Lames émoussées, pour prendre
Las cuchillas romas, para tomar

Medial
médian
medio



mm

AP-2357-40 40 x 20
AP-2357-45 45 x 20
AP-2357-50 50 x 20
AP-2357-55 55 x 20
AP-2357-60 60 x 20



mm

AP-2358-35 35 x 52
AP-2358-40 40 x 52
AP-2358-45 45 x 52
AP-2358-50 50 x 52
AP-2358-55 55 x 52
AP-2358-60 60 x 52
AP-2358-65 65 x 52
AP-2358-70 70 x 52



mm

AP-2359-35 35 x 37
AP-2359-40 40 x 37
AP-2359-45 45 x 37
AP-2359-50 50 x 37
AP-2359-55 55 x 37
AP-2359-60 60 x 37
AP-2359-65 65 x 37
AP-2359-70 70 x 37



mm

AP-2360-35 35 x 22
AP-2360-40 40 x 22
AP-2360-45 45 x 22
AP-2360-50 50 x 22
AP-2360-55 55 x 22
AP-2360-60 60 x 22
AP-2360-65 65 x 22
AP-2360-70 70 x 22



mm

AP-2361-50 50

Hook



mm

AP-2362-70

Neuro and Laminectomy Instruments

Lamina Spreaders
Lamina Spreader

Epandage lamina
Separadores de Lamina



Retractor Only
Retractor Nur
Seulement écarteur
Sólo Retractor

AP-2363-01
12 cm/4¾"

Caspar
AP-2363-00
AP-2364-40
AP-2365 -00

Retractor Complete With 1 Blade Each
Retractor komplett mit 1 Klinge Jeder
Écarteur complet avec Chaque lame 1
Retractor completo con Cada una hoja

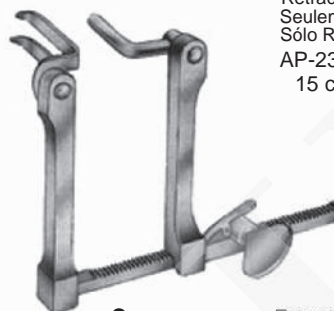

Retractor Only
Retractor Nur
Seulement écarteur
Sólo Retractor

AP-2366-01
15 cm/6"

Caspar
AP-2366-00
AP-2367-40
AP-2368-50

Retractor Complete With 1 Blade Each
Retractor komplett mit 1 Klinge Jeder
Écarteur complet avec Chaque lame 1
Retractor completo con Cada una hoja

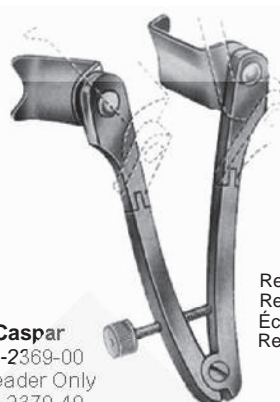

Spreader Only
Spreader Nur
épandeur seulement
Sólo Spreader
AP-2369-01

Caspar
AP-2369-00
Spreader Only
AP-2370-40
AP-2371-40

Retractor Complete With 1 Blade Each
Retractor komplett mit 1 Klinge Jeder
Écarteur complet avec Chaque lame 1
Retractor completo con Cada una hoja

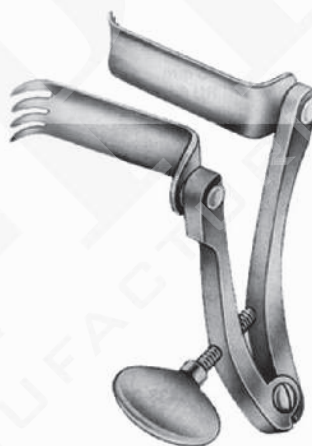

Spreader Only
Spreader Nur
épandeur seulement
Sólo Spreader
AP-2372-01

Caspar
AP-2372-00
Retractor Only
Retractor Nur
Seulement écarteur
Sólo Retractor

Spreader Complete With 1 Blade Each
Spreader komplett mit 1 Klinge Jeder
Épandeur complet avec 1 lame Chaque
Spreader completo con una cuchilla Cada
AP-2373-45
AP-2374-60

Retractor Only
Retractor Nur
Seulement écarteur
Sólo Retractor
AP-2375-01
15 cm/6"

Caspar
AP-2375-00
AP-2376-45
AP-2377-65

Retractor Complete With 1 Blade Each
Retractor komplett mit 1 Klinge Jeder
Écarteur complet avec Chaque lame 1
Retractor completo con Cada una hoja



Retractor Only
Retractor Nur
Seulement écarteur
Sólo Retractor
AP-2378-01
15 cm/6"

Caspar
AP-2378-00
AP-2379-45
AP-2379-65

Retractor adjustable, con 1 blade each
Retractor einstellbar, con 1 Klinge jedes
Écarteur réglable, con 1 lame à chaque
Separador ajustable, con una hoja cada

Neuro and Laminectomy Instruments

Lamina Spreaders
Lamina Spreader

Epandage lamina
Separadores de Lamina



Cloward
AP-2380-00
15 cm/6"

Complete with 5 blades
Komplett mit 5 Klingen
Livré avec 5 lames
Completo con 5 cuchillas

AP-2380-01
Retractor Only
Retractor Nur
Seulement écarteur
Solo Retractor



AP-2381-01
Retractor Only
Retractor Nur
Seulement écarteur
Solo Retractor

Cloward
AP-2381-00
25 cm/10"

Complete with 5 blades
Komplett mit 5 Klingen
Livré avec 5 lames
Completo con 5 cuchillas



AP-2380-40
15x40 mm



AP-2380-45
15x45 mm



AP-2380-50
15x50 mm



AP-2380-55
15x55 mm



AP-2380-60
15x60 mm



AP-2381-40
15x40 mm



AP-2381-45
15x45 mm



AP-2381-50
15x50 mm



AP-2381-55
15x55 mm

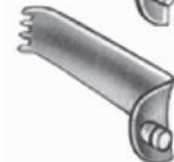

AP-2381-60
15x60 mm

Neuro and Laminectomy Instruments

Lamina Spreaders
Lamina Spreader

Epan dage lamina
Separadores de Lamina

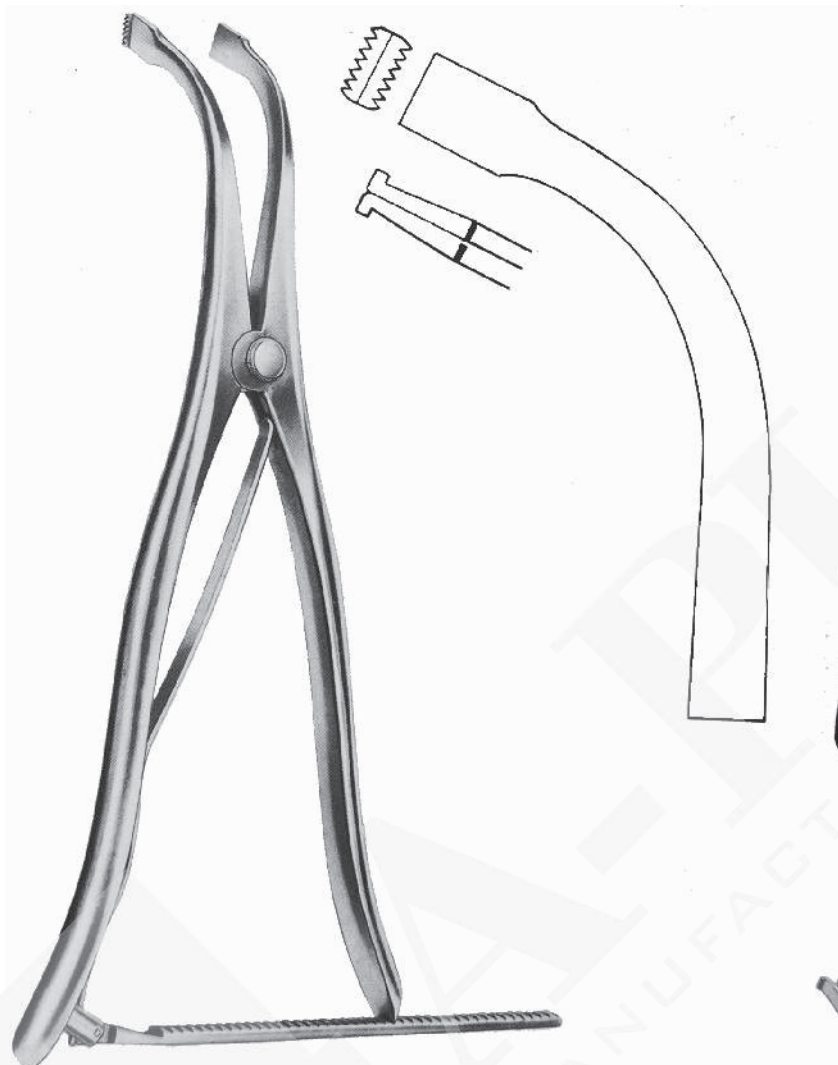

Inge
AP-2382-27
27 cm/10³/₄"

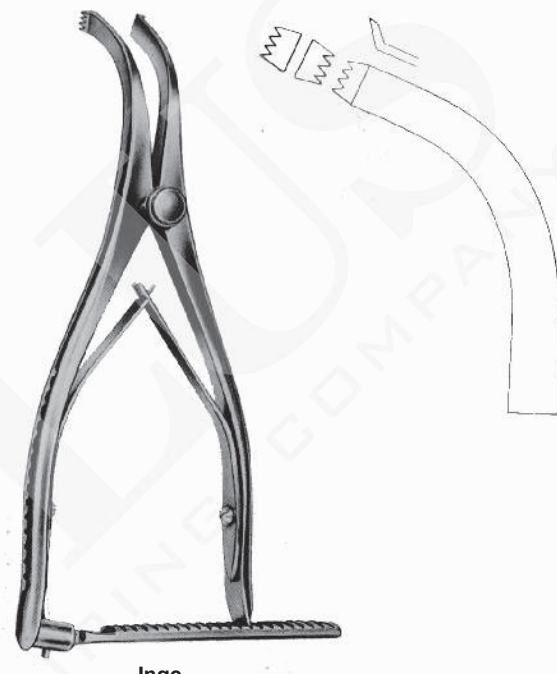

Inge
AP-2383-16
16 cm/6¹/₄"



Cloward
AP-2384-16
16 cm/6¹/₄"

Neuro and Laminectomy Instruments

Lamina Spreaders
Lamina Spreader

Ependage lamina
Separadores de Lamina



Frame
AP-2385-01

Hey
AP-2385-00
AP-2386-00
23 cm/9"

Muscle blades
Muscle Klängen
lames musculaires
hojas musculares

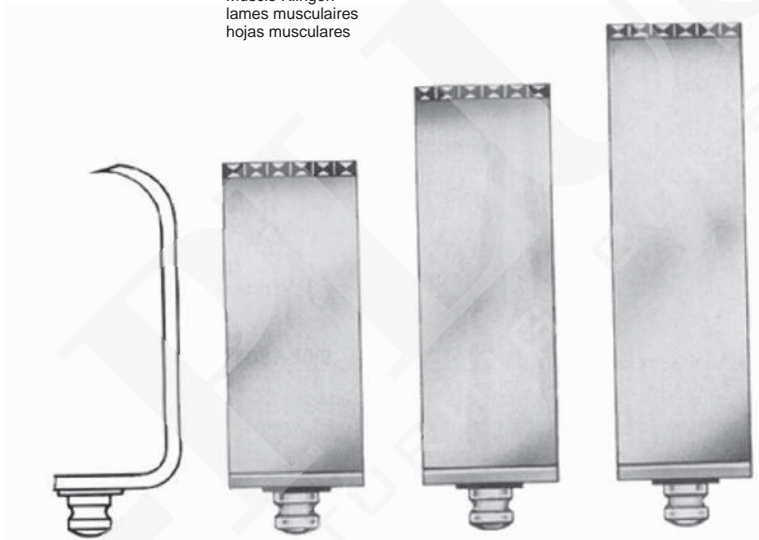

AP-2385-50
20x50 mm

AP-2385-60
20x60 mm

AP-2385-70
20x70 mm

Vertebra-pins
Wirbel-pins
vertèbres broches
vértebras-pins

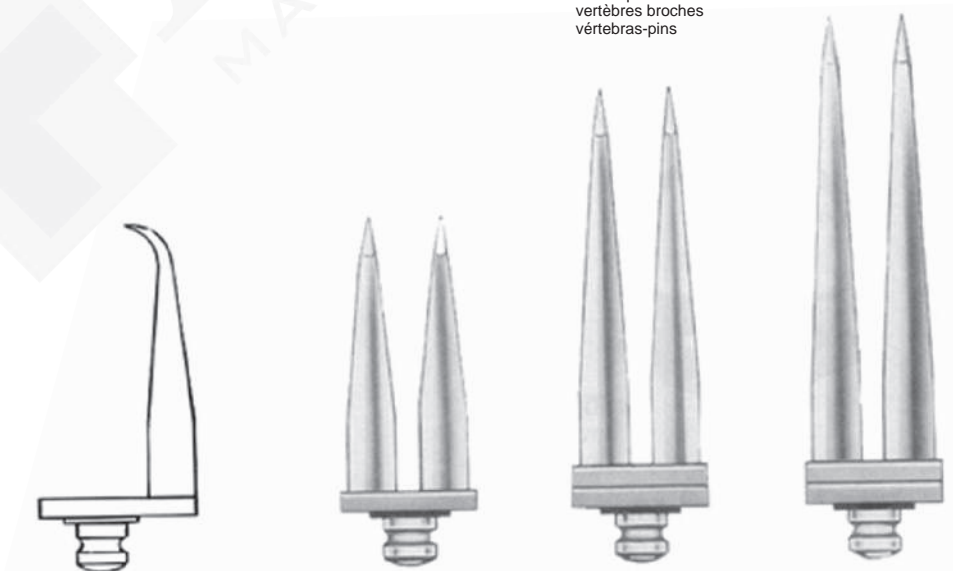

AP-2386-50
50 mm

AP-2386-60
60 mm

AP-2386-70
70 mm

Neuro and Laminectomy Instruments

Lamina Spreaders
Lamina Spreader

Epan dage lamina
Separadores de Lamina

Left-type
Left-Typ
Gauche type
De tipo izquierdo



17 cm/6³/₄"

Right-type
Rechts-Typ
Droit de type
Haga tipo



17 cm/6 ³/₄"

Left-type
Left-Typ
Gauche type
De tipo izquierdo

50x10 mm

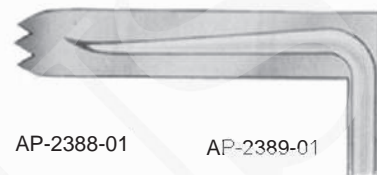

AP-2388-01

Right-type
Rechts-Typ
Droit de type
Haga tipo

AP-2389-01

60x10 mm



AP-2388-02

AP-2389-02

70x10 mm



AP-2388-03

AP-2389-03

50x20 mm

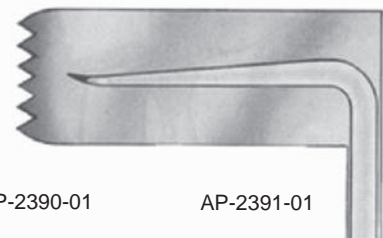

AP-2390-01

AP-2391-01

60x20 mm

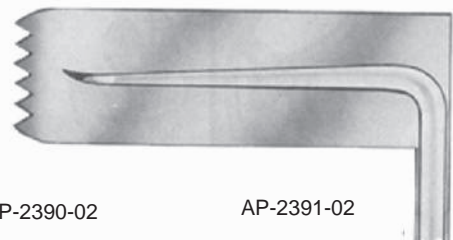

AP-2390-02

AP-2391-02

70x20 mm

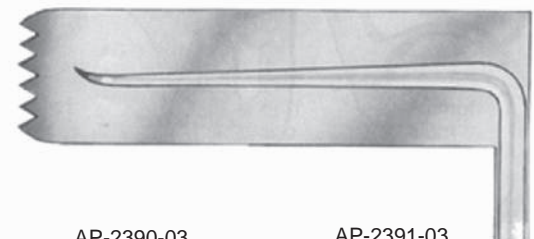

AP-2390-03

AP-2391-03

Neuro and Laminectomy Instruments

Muscle Retractors
Muscle Retraktoren

Rétracteurs musculaires
Los retractoros del músculo



Henly

Complete Consisting of
bestehend aus vervollständigen
composée d' compléter
Compuesto por completar

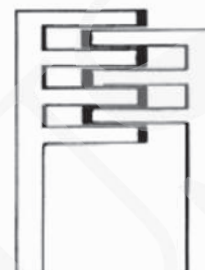

Standard

AP-2392-00
14.5 cm/5¾"

AP-2393-00
17 cm/6¾"

16 x 19 mm AP-2392-01
16 x 25 mm AP-2392-21
16 x 32 mm AP-2392-22
AP-2392-23

AP-2393-01
AP-2393-21
AP-2393-22
AP-2393-23

Frame
Centre Blades
Zentrum Blades
Lames Centre
Hojas Centro

16 x 19 mm

16 x 25 mm

16 x 32 mm

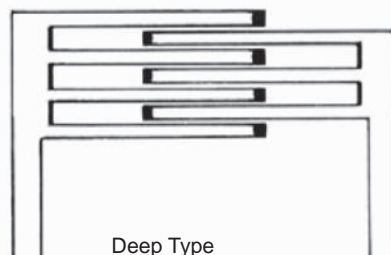

Deep Type

Complete Consisting of
bestehend aus vervollständigen
composée d' compléter
Compuesto por completar

AP-2394-00 14.5 cm/5¾" AP-2395-00 17 cm/6¾"

AP-2394-01
AP-2394-21
AP-2394-22
AP-2394-23

AP-2395-01
AP-2395-21
AP-2395-22
AP-2395-23

Centre Blades
Zentrum Blades
Lames Centre
Hojas Centro

Neuro and Laminectomy Instruments

Brain Retractors
Gehirn-Reraktoren

Rétracteurs cerveau
Los retractoros del cerebro

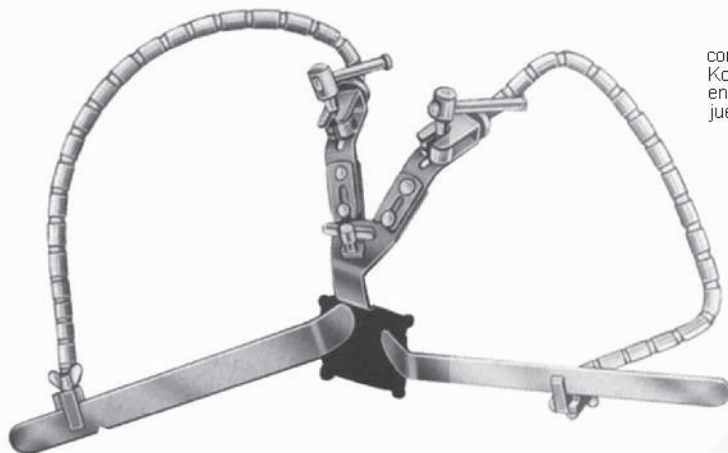

complete set
Komplett-Set
ensemble complet
juego completo

Yasargil
AP-2396-00
2 AP-2396-01
1 AP-2396-02
2 AP-2396-03

Self-retaining brain retractor, with 2 flexible arms, complete, consisting of:
Selbsthaltung Gehirn Retraktor mit 2 flexiblen Armen, komplett, bestehend aus:
Écarteur autostatique cerveau, avec 2 bras flexibles, complets, consistant en:
Auto-retención cerebro retractor, con 2 brazos flexibles y completos, que consiste en:

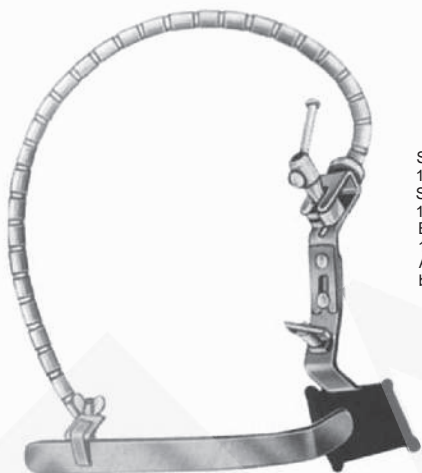

Yasargil
AP-2397-00
1 AP-2397-01
1 AP-2397-02
1 AP-2397-10

Self-retaining brain retractor, with 1 flexible arm, complete, consisting of:
Selbsthaltung Gehirn Retraktor mit 1 flexiblen Arm, komplett, bestehend aus:
Écarteur autostatique cerveau, avec 1 bras flexible, complet, consistant en:
Auto-retención cerebro retractor, con un brazo flexible, completa, que consiste en:



AP-2398-10

wire cable only
Draht-Kabel nur
câble métallique ne
alambre cable sólo



AP-2398-01

Fixation base, for skull mounting, holding 1 flexible arm
Fixation Base, Schädel-Montage, Halten 1 flexiblen Arm
Base de fixation, pour le montage du crâne, détenant 1 bras flexible
Base de fijación, para el montaje del cráneo, la celebración de un brazo flexible

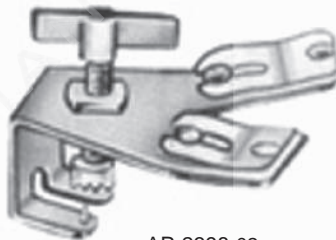

AP-2398-02

Fixation base, for skull mounting, holding 2 flexible arms
Fixation Base, Schädel-Montage, Halten 2 flexiblen Armen

Base de fixation, pour le montage du crâne, n'excedant pas 2 bras flexibles
Base de fijación, para el montaje del cráneo, la celebración de dos brazos flexibles



AP-2398-03

Support only, flat brain spatulas,
Unterstützen nur, flache Gehirn Spatel,
Prennent en charge que le cerveau, spatules plates,
Apoyo espátulas, el cerebro sólo planos,



AP-2398-04

Support only, for brain spatulas with round shaft up to 5,5 mm diam. Fixing for flexible
Unterstützt nur für Gehirn-Spatel mit runden Wellenenden bis 5,5 mm Durchmesser. Befestigung für flexible
Prennent uniquement en charge, pour spatules cerveau avec tige ronde jusqu'à 5,5 mm de diamètre. Fixation pour flexibles
Único apoyo, para espátulas cerebrales con eje redondo hasta un diámetro de 5,5 mm. La fijación de criterios flexibles



Neuro and Laminectomy Instruments

Intervertebral Disc Rongeurs
Inter Bandscheibe Rongeur

Rongeurs disques intervertébraux
Los roedores del disco intervertebral



Ferris-Smith-Kerrison

	Width of Bite Breite der Biss Largeur de Bite Ancho de Bite	Length of Shaft Länge der Welle Longueur de l'arbre Longitud del eje		
	15 cm/6"	20 cm/8"	18 cm/7"	
	0.6 mm		AP-2401-00	
	1 mm		AP-2401-01	
	2 mm		AP-2401-02	
	3 mm	AP-2399-03	AP-2400-03	AP-2401-03
	4 mm		AP-2400-05	AP-2401-04
	5 mm	AP-2399-05	AP-2401-05	
			AP-2404-00	
	0.6 mm		AP-2404-01	
	1 mm		AP-2404-02	
	2 mm		AP-2404-03	
	3 mm	AP-2402-03	AP-2403-03	AP-2404-04
	4 mm		AP-2403-05	AP-2404-05
	5 mm	AP-2402-05		
			AP-2407-00	
	0.6 mm		AP-2407-01	
	1 mm		AP-2407-02	
	2 mm		AP-2407-03	
	3 mm	AP-2405-03	AP-2406-03	AP-2407-04
	4 mm		AP-2406-05	AP-2407-05
	5 mm	AP-2405-05		

Neuro and Laminectomy Instruments

Intervertebral Disc Rongeurs
Inter Bandscheibe Rongeur

Rongeurs disques intervertébraux
Los roedores del disco intervertebral



Ferris-Smith-Kerrison

		Width of Bite Breite der Biss Largeur de Bite Ancho de Bite	15 cm/6"	20 cm/8"	18 cm/7"
Cutting Upward Schneiden nach oben couper vers le haut Cortar hacia arriba...		3 mm 5 mm	AP-2408-03 AP-2408-05	AP-2409-03 AP-2409-05	AP-2410-03 AP-2410-05
Cutting Upward 40° Schneiden Upward 40° Couper vers le haut 40° Cortar hacia arriba 40°		3 mm 5 mm	AP-2411-03 AP-2411-05	AP-2412-03 AP-2412-05	
Cutting Downwards Schneiden Downwards En contrebas de coupe Hacia abajo de Corte		3 mm 5 mm	AP-2413-03 AP-2413-05	AP-2414-03 AP-2414-05	AP-2415-03 AP-2415-05

Neuro and Laminectomy Instruments

Intervertebral Disc Rongeurs
Inter Bandscheibe Rongeur

Rongeurs disques intervertébraux
Los roedores del disco intervertebral



Schaftlänge Length of shaft Largo de vastago Schaftlänge Länge der Welle Largo de vastago Longueur de l'arbre Schaftlänge Largo vastago de Schaftlänge Longitud del eje Largo de vastago	150 mm 6"	190 mm 8"	150 mm 6"	190 mm 8"
BiBbreite Width of Bite Ancho de la boca BiBbreite Breite der Biss Ancho de la boca Largeur BiBbreite de Bite Ancho de boca la Ancho BiBbreite de Bite Ancho de la boca	3 mm	3 mm	5 mm	5mm
Art-Nr. Cat. Ref.	AP-2416-03	AP-2417-03	AP-2418-06	AP-2419-06

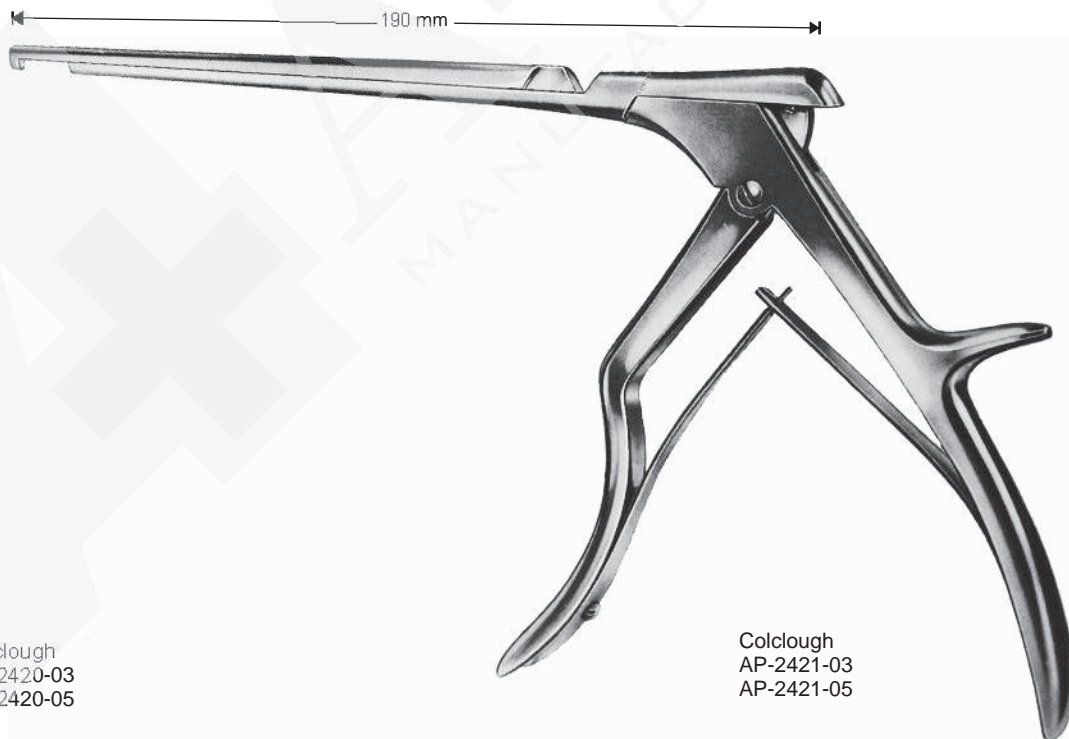

Colclough
AP-2420-03
AP-2420-05

Colclough
AP-2421-03
AP-2421-05

Neuro and Laminectomy Instruments

Laminectomy Rongeurs
Laminektomiestanzen

Rongeurs laminectomie
Rongeurs laminectomia

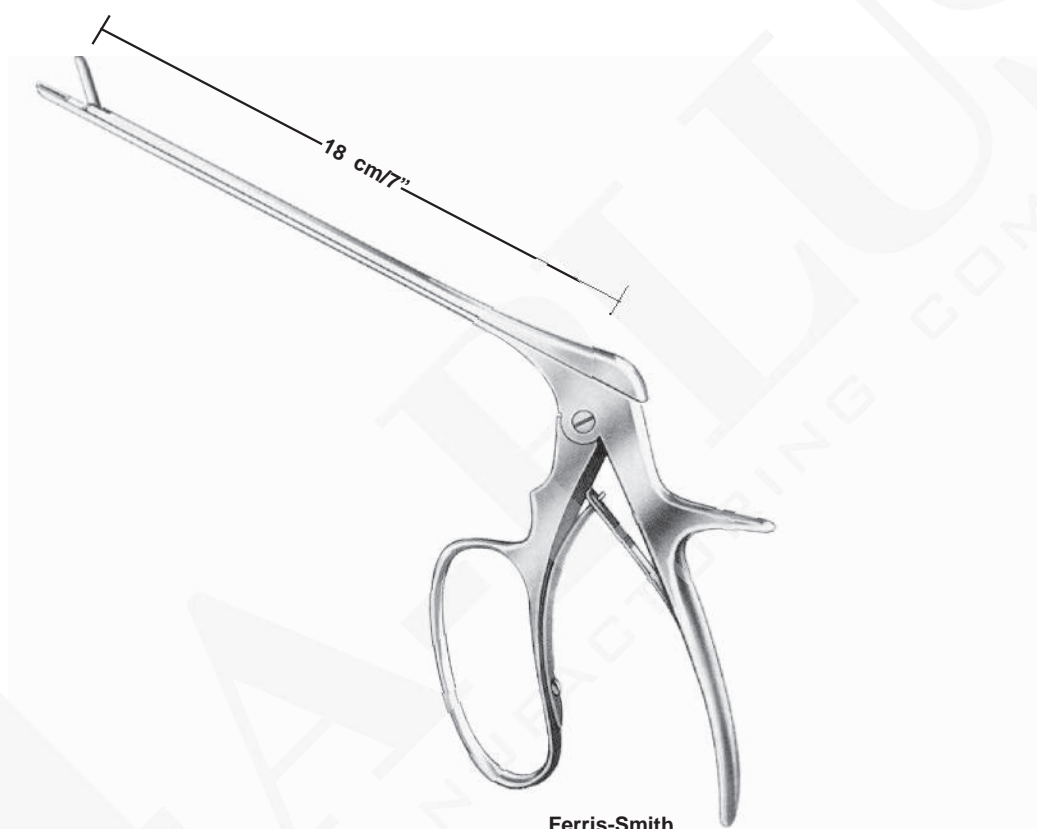

Ferris-Smith



Width Of Jaw
Width Of Jaw
Veulent consacer la mâchoire
Width de la mandibula

2 x 10 mm	AP-2422-02	AP-2423-02	AP-2424-02
3 x 10 mm	AP-2422-03	AP-2423-03	AP-2424-03
4 x 10 mm	AP-2422-04	AP-2423-04	AP-2424-04

Neuro and Laminectomy Instruments

Laminectomy Rongeurs
Laminektomiestanzen

Rongeurs laminectomie
Rongeurs laminectomía

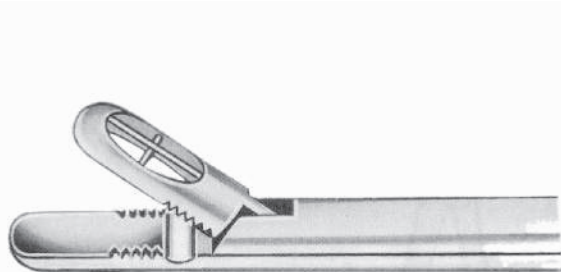

Serrated and Fenestrated Jaws
Serrated und Fenestrated Jaws...
Dentelé et Jaws fenêtrée
Dentada y mordazas fenestradas

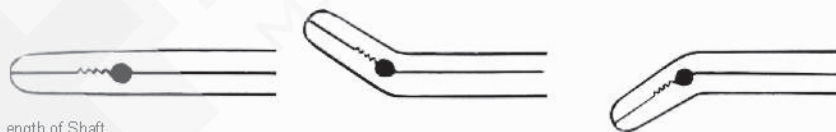

Width Of Jaw
Width Of Jaw
Veulent consacrer la mâchoire
Widh de la mandíbula

Length of Shaft
Länge der Welle
Longueur de l'arbre
Longitud del eje

mm	14 cm/5 1/2"	AP-2425-01	AP-2425-02	AP-2425-03
2 x 12	16 cm/6 1/4"	AP-2426-01	AP-2426-02	AP-2426-03
3 x 12	14 cm/5 1/2"	AP-2427-01	AP-2427-02	AP-2427-03
	16 cm/6 1/4"	AP-2428-01	AP-2428-02	AP-2428-03
4 x 14	14 cm/5 1/2"	AP-2429-01	AP-2429-02	AP-2429-03
	16 cm/6 1/4"	AP-2430-01	AP-2430-02	AP-2430-03
5 x 14	14 cm/5 1/2"	AP-2431-01	AP-2431-02	AP-2431-03
	16 cm/6 1/4"	AP-2432-01	AP-2432-02	AP-2432-03
6 x 16	14 cm/5 1/2"	AP-2433-01	AP-2433-02	AP-2433-03
	16 cm/6 1/4"	AP-2434-01	AP-2434-02	AP-2434-03

Neuro and Laminectomy Instruments

Laminectomy Rongeurs
Laminektomiestanzen

Rongeurs laminectomie
Rongeurs laminectomia



AP-2435-01
5 x 4 mm



AP-2435-02
5 x 4 mm



AP-2435-03
5 x 3.5 mm

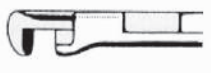

AP-2435-04
5 x 3.5 mm

Hajek
(Hajek-Kofler)
14 cm/5½"



Hajek-Kofler
AP-2436-16
16 cm/6½"

360° Turnable
360° Drehbare
360° Turnable
360° Turnable

Neuro and Laminectomy Instruments

Laminectomy Rongeurs
Laminektomiestanzen

Rongeurs laminectomie
Rongeurs laminectomía

Ø 6.5 mm



Oldberg
AP-2437-65
18 cm/7"

Ø 3.5 mm

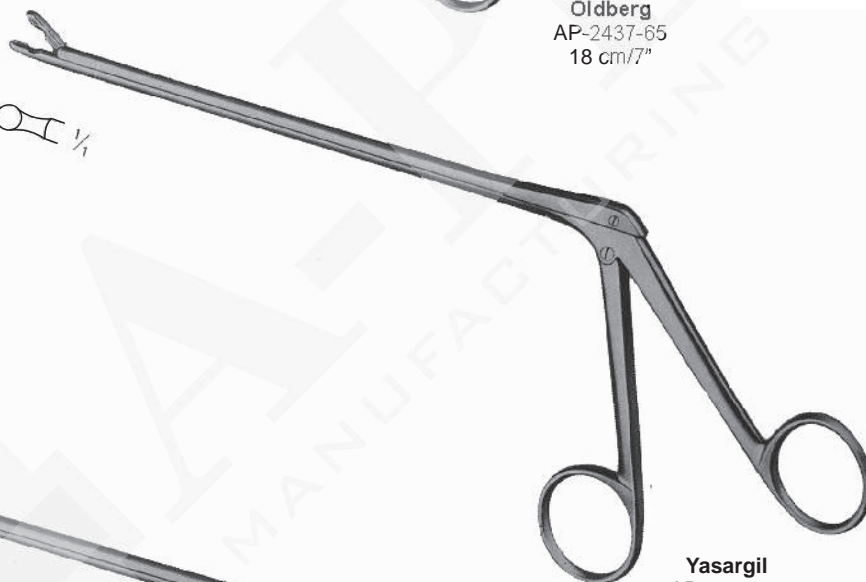

Yasargil
AP-2438-19
19.5 cm/7¾"

Ø 9 mm



Landolt
AP-2439-21
21 cm/8¼"

Tumor Grasping Forceps Blunt
Tumor Faßzange Blunt
Tumeur pince à préhension Blunt
Tumor Entender Pinzas Blunt



Manufacturing Company

**Manufacturers & Exporters of Surgical,Dental,Veterinary,Manicure
Pedicure Instruments & Scissors of All Sorts**

Iqbal Town, Defence Road, Sialkot 51310 - Pakistan.

Tel : +92-52-3254596 Fax : +92-52-3563444

E-mail : info@aplus.com.pk

Web : www.aplus.com.pk